



WOHWA Belt Feeders/Batching Combinations

for poorly flowing bulk materials

Features/Benefits

- Motors easily replaceable
- Robust design
- Hardox wear resisting lining optionally
- Material flow controller
- Adjustable PU sealings (Vulkollan®)
- Fully galvanized
- Self-adjusting belt cleaner
- Plough cleaner for return belt
- Crowned pulleys
- Shafts bolted to pulleys
- Belt speed adjustment range approx. 1:20
- Robust helical bevel gear unit
- Easily replaceable endless belt
- Feed rate adjustable

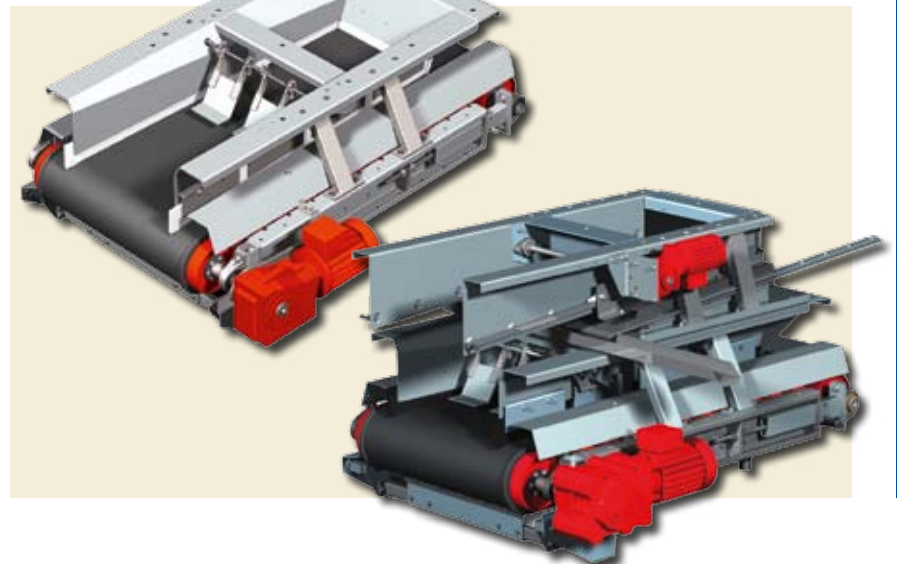

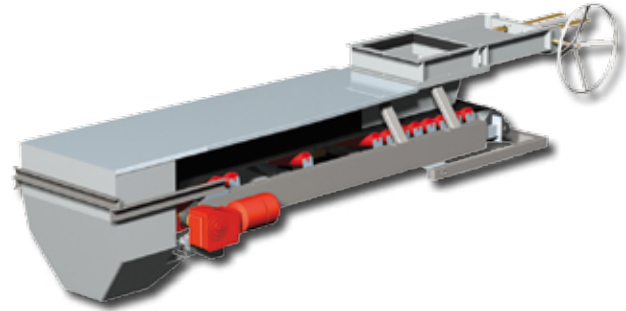

WOHWA Belt Feeders, Batching Combinations

Professionalism

WOHWA Belt Feeders have a modular design allowing for a high degree of flexibility, easy maintenance and short delivery times. All components are hot-dip galvanized, manufactured at the plant in Germany, and adaptable to individual customer requirements.

- Robust design
- Maintenance-free gear unit/bearings
- All bearings lubricated for life
- All parts hot-dip galvanized
- Center distance individually extendable

The new “tight transfer box” prevents material from spilling between discharge gate and belt feeder so that the mechanical parts of the discharge gate cannot get soiled. All parts of the discharge gate are freely accessible. Discharge gate and belt feeder components can be exchanged, even with stockpiled material above.



WOHWA Belt Feeders in Mineral Processing Plant

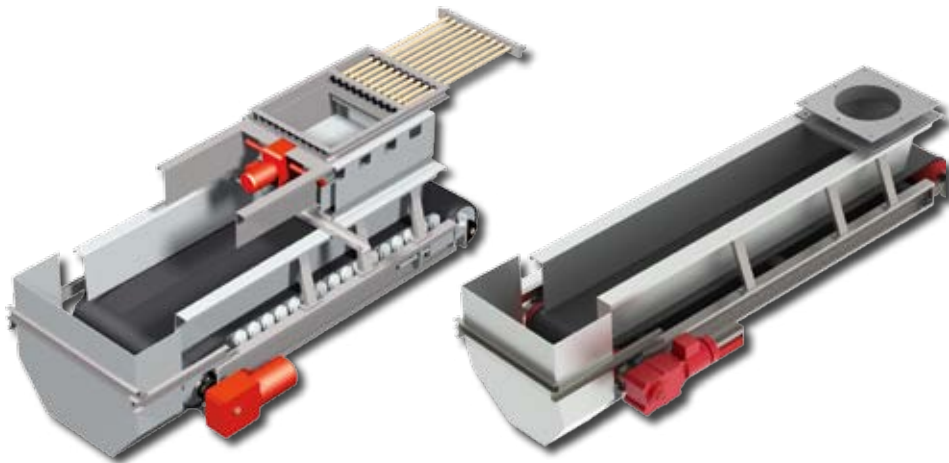

Applications

WOHWA Belt Feeders can be safely used for poorly flowing (e.g., sand) or coarse bulk materials required for small loadout quantities with minor portions in a recipe. Desired percentages in aggregate blends can be achieved by using frequency converters to obtain variable belt speeds. Standard

Industrial Duty



Belt Feeder Industrial Duty Flat Belt

Belt feeders for blending precise proportions of poorly flowing bulk materials, e.g., wet sand and coarse materials up to approx. 8 inches (200 mm).

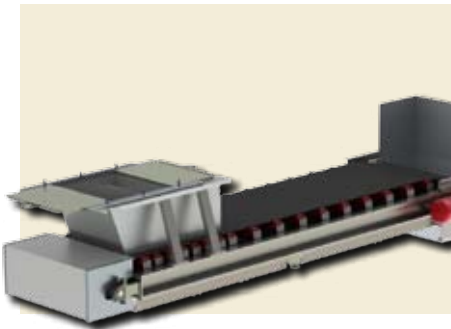

Belt Feeder Industrial Duty Troughed Belt with Push-Pull Slide Gate Type 09.

Belt feeders for blending precise proportions of poorly flowing bulk materials, e.g., wet sand and coarse materials up to approx. 8 inches (200 mm).

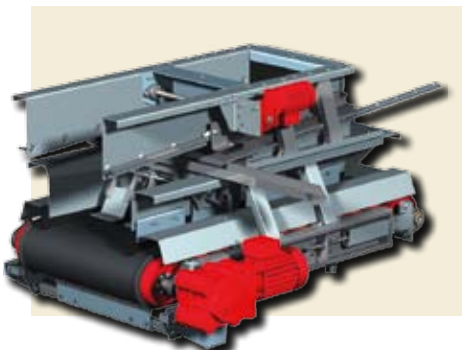

Batching Combination Standard Flat Belt

Belt feeder in combination with a discharge gate type 01.1 with water drainage for very wet and poorly flowing bulk materials such as sands. Mostly used for tunnel reclaim below stockpiles.



reclaim/feed quantities of 3 to 2 000 t/h can be attained, dependant on belt width, height of material carpet, particle sizes and flow characteristics. Corrugated side wall belts or trapezoidal flat belts are used for an optimized material feed

Drive mechanism

All drive components have been carefully selected and matched for a reliable driving power.

- 0.1-15 kW-motor
- Robust helical bevel gear unit
- Slip-on gear drive
- Wide adjustment range when used with frequency converter (approx. 1:20)

System integration

Equipped with frequency converters, WOHWA Belt Feeders can be connected to any control system either analogically, digitally or via PROFIBUS DP.

All WOHWA Belt Feeders can be combined with WOHWA discharge gates.

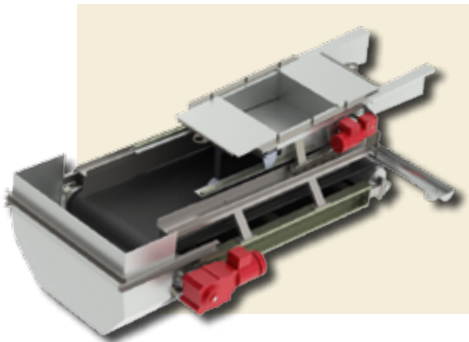

Batching Combination Compact Version

Belt feeder in combination with a discharge gate type O1.1 with water drainage for very wet and poorly flowing bulk materials, e.g., sand. For installation in locations with restricted height.

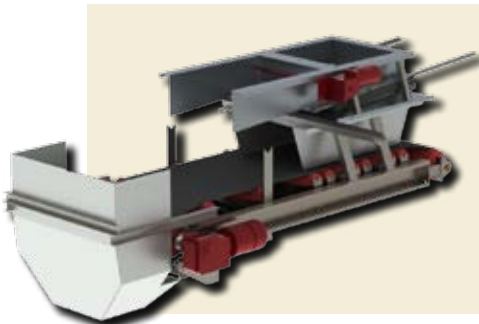

Batching Combination Standard Troughed Belt

Belt feeder in combination with a discharge gate type O1.1 with water drainage for very wet and poorly flowing bulk materials, e.g., sand. Mostly used for tunnel reclaim below stockpiles..

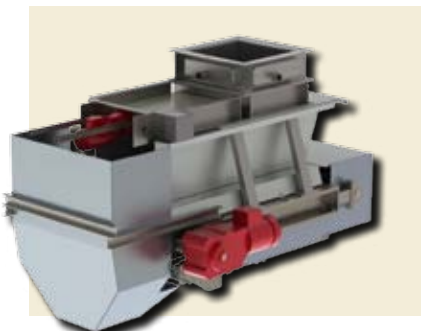

Batching Combination with additional water-drainage insert box Standard Flat Belt

Belt feeder in combination with a discharge gate type O8 with water drainage. For very wet and poorly flowing bulk materials, e.g., sand. Mostly used for tunnel reclaim below stockpiles.

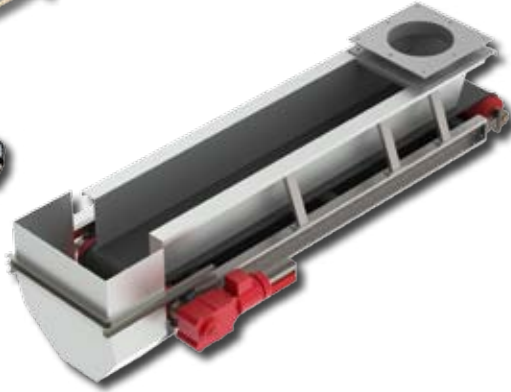
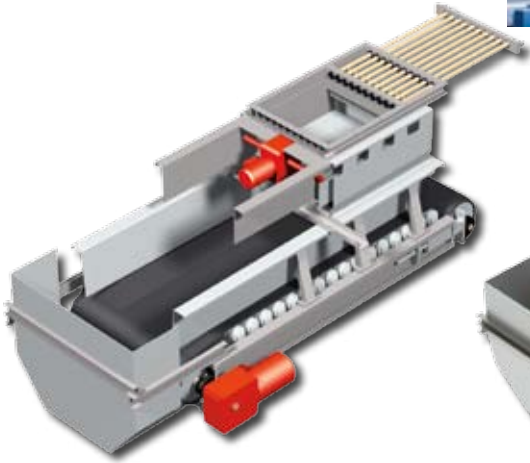

Heavy Duty

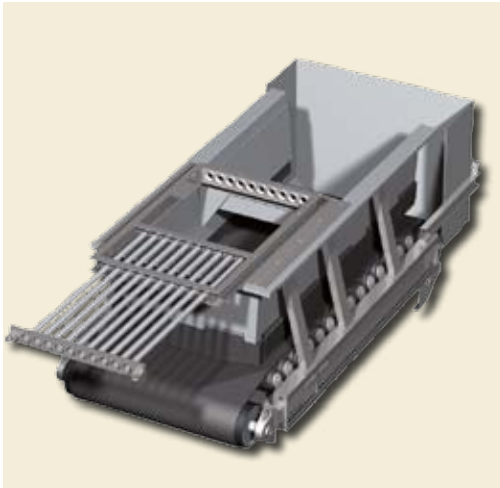

Belt Feeder Heavy Duty Troughed Belt with Pin Gate

Belt Feeders in robust design for use in very rough conditions, e.g., in mining.

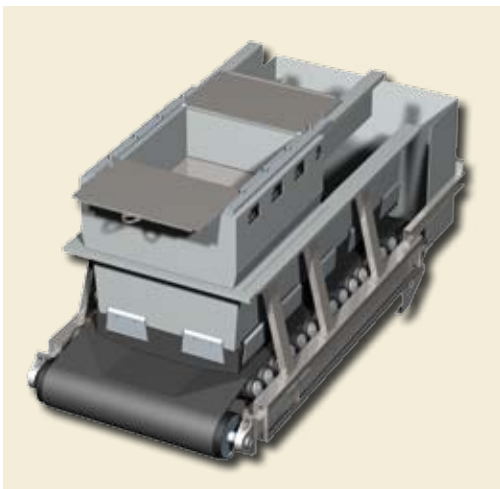

Batching Combination Heavy Duty Troughed Belt

Batching Combination with Heavy Duty Slide Gate Type 01 and water drainage. For very wet and poorly flowing bulk materials, e.g., sand. Mostly used in tunnels.



WOHWA Waagenbau GmbH
Öhringer Str. 6 · 74629 Pfedelbach · GERMANY
Phone +49 7941 9131-0 · Fax +49 7941 9131-28
info@woehwa.com · www.woehwa.com

WOHWA Options for Belt Feeders, Batching Combinations



Chute



Safety Guard



Material Flow Controller



Special Motors



Covers and Casings

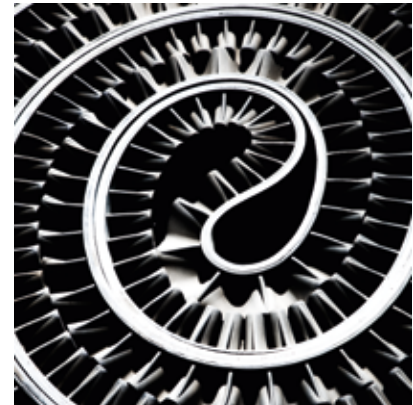

Corrugated Side Wall Belt



Pull Cord Switch



Lagged Drive Pulley



Wear Resisting Lining